

# The optomechanical design of the Giant Magellan Telescope Multi-object Astronomical and Cosmological Spectrograph (GMACS)

Travis Prochaska<sup>\*a</sup>, Carson Albert<sup>a</sup>, James Beck<sup>a</sup>, Erika Cook<sup>a</sup>, D. L. DePoy<sup>a</sup>, Daniel M. Faes<sup>b</sup>, Cynthia Froning<sup>c</sup>, Walter Grant<sup>a</sup>, Isaac Gutierrez<sup>a</sup>, Tae-Geun Ji<sup>f</sup>, Damien Jones<sup>d</sup>, Hye-In Lee<sup>f</sup>, Jennifer L. Marshall<sup>a</sup>, Claudia Mendes de Oliveira<sup>b</sup>, Soojong Pak<sup>f</sup>, Casey Papovich<sup>a</sup>, Rafael Ribeiro<sup>b</sup>, Marcus Sauseda<sup>a</sup>, Luke M. Schmidt<sup>a</sup>, Aline Souza<sup>b</sup>, Keith Taylor<sup>c</sup>, Darius Williams<sup>a</sup>

<sup>a</sup>Department of Physics & Astronomy, Texas A&M University, 4242 TAMU, College Station, TX 77843-4242; <sup>b</sup>Departamento de Astronomia, IAG, Universidade de São Paulo, Cidade Universitária, 05508-900, São Paulo, Brazil; <sup>c</sup>Instruments4, CA 91011, USA; <sup>d</sup>Prime Optics, Australia; Department of Astronomy, C1400, <sup>e</sup>University of Texas at Austin, Austin, TX 78712; <sup>f</sup>School of Space Research, Kyung Hee University, Yongin-si, Gyeonggi-do 17104, Republic of Korea

## ABSTRACT

We describe the latest optomechanical design of GMACS, a wide-field, multi-object, moderate-resolution optical spectrograph for the Giant Magellan Telescope (GMT). Specifically, we discuss the details of the structure, mechanisms, optical mounts and deflection tracking/compensation as well as the requirements and considerations used to guide the design. We also discuss GMACS's interfaces with GMT and other instruments.

**Keywords:** multi-object spectrograph, camera, CCD, VPH grating, Giant Magellan Telescope

## 1. INTRODUCTION

GMACS (Giant Magellan Telescope Multi-object Astronomical and Cosmological Spectrograph) is a first light instrument for the Giant Magellan Telescope (GMT)<sup>[1]</sup>. It will be mounted at the Gregorian focus of the GMT as illustrated in Figure 1. GMACS is a wide field, multi-object, moderate-resolution, optical spectrograph capable of observing the faintest possible targets, those that are substantially fainter than the sky. High throughput, simultaneous wide wavelength coverage, accurate and precise sky subtraction, moderate resolution, and wide field are the crucial design drivers for the instrument.

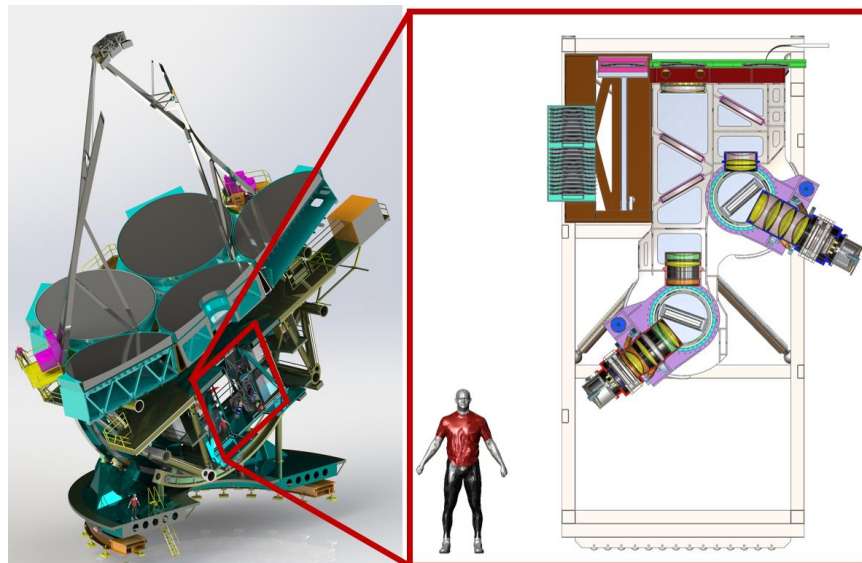

Figure 1. Location of the GMACS instrument within GMT.

<sup>\*</sup> tprochaska@physics.tamu.edu; Phone 1-979-862-2747; <http://instrumentation.tamu.edu/>

The optical performance specifications for GMACS have been developed through collaboration with GMTO, partner institutions and members of the scientific community. The minimum specifications are listed in Table 1 along with stricter specifications we hope to achieve. More details on the current conceptual optical design<sup>[2]</sup> can be found in SPIE paper 10702-340.

Table 1. List of GMACS functional specifications.

Parameter	Requirement
Field of View	30-50 arcmin sq.
Wavelength Coverage	Blue cut-off: 320-350 nm
	Red cut-off: 950-1000 nm
Dichroic Transition Wavelength	558 nm
Spectral Resolution	Blue: 1000-6000, Red 1000-6000
Image Quality	80% EE at 0.15-0.30 arcsec diameter
Spectral Stability	0.1-0.3 spectral resolution elements/hour
Number of Gratings	$\geq 2$
Slit Mask Exchange	Min: 12; Desired > 20

The current GMACS conceptual design is an evolution from the previous designs that were first described in SPIE proceedings in 2012<sup>[3]</sup>. The current design in this paper uses a split collimator as opposed to a single collimator from the 2016 conceptual design<sup>[4]</sup>. This design change is driven by the desire for higher blue throughput and to help stay within our volume constraints. The final instrument architecture (split or single collimator) will be selected after an optical trade study is complete. The scope of the conceptual optomechanical design is to illustrate how the optics and subsystems will be packaged, to simulate articulation ranges of the moving components and identify potential collisions, estimate initial instrument envelope and weight (Figure 2), investigate GMT interfacing, and determine expected deformations. Much of this will be used to feed back to the optical design's development.

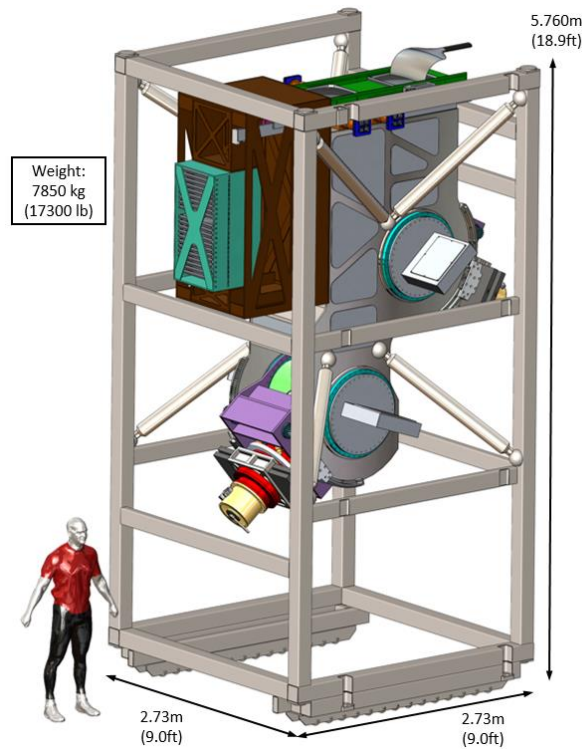

Figure 2. Overall size and weight of GMACS.

## 2. INSTRUMENT MOUNTING

### 2.1 GMT mechanical interface

The GMT mechanical interface is currently planned to be supported by the Gregorian Instrument Rotator (GIR). The GIR will enable GMACS and other instruments to attach to the back of the telescope at the Gregorian focus as well as de-rotate the instrument to track the field. This system will also store and engage instruments automatically. The GIR holds an instrument in the optical path by engaging lifts from its floor and compressing the instrument against pads on its top plate. This effectively means that GMACS will be held at the top and bottom of its frame and will no longer be cantilevered, as it was in previous GMACS conceptual designs.

### 2.2 Frame

GMACS's current frame design (Figure 3) is comprised of three subcomponents: the Instrument Mounting Frame (IMF), Optical Bench, and connecting tubes. The IMF is designed to be compatible with the GIR's instrument positioning and clamping system, the optics bench holds the instrument subassemblies, and the tubes connect the optics bench to the IMF with a MERO<sup>[5]</sup> style attachment system. This frame will be very stiff and will help evenly distribute the instrument load to the GIR.

The IMF will be a welded tube structure and should be relatively straightforward to fabricate. The optics bench will be made of plates that are pinned and bolted together. Welding was considered, but the warping induced by welding will likely be unacceptable. All the frame components will be made of steel for its strength, stiffness, availability, machinability, weldability and cost. The design of this system is still being optimized to reduce mass and simplify the load paths.

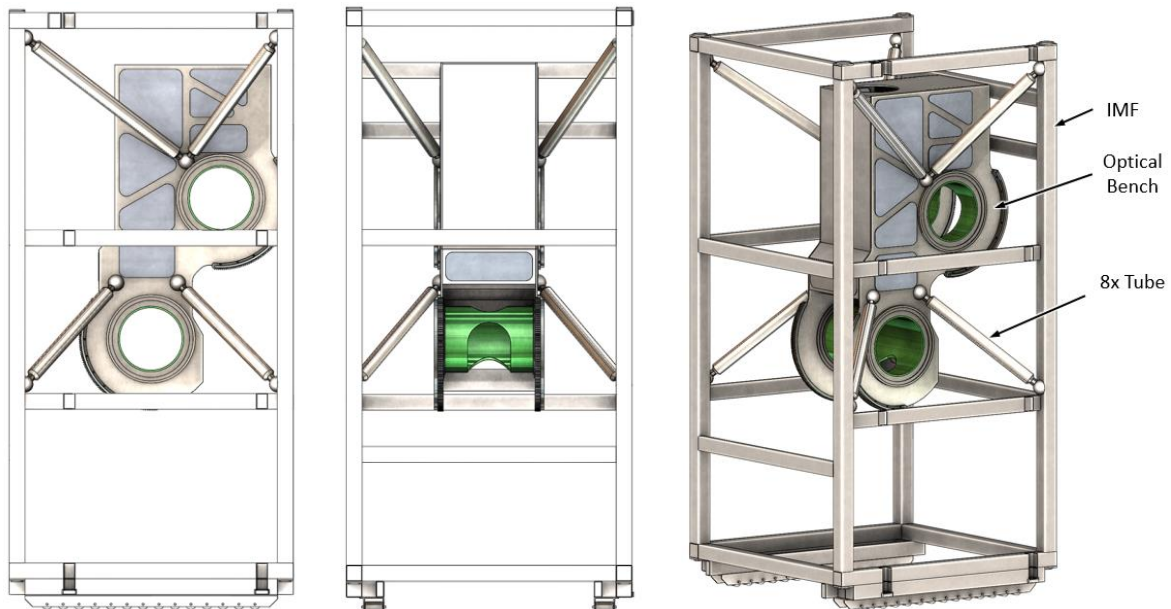

Figure 3. Front, side and diagonal view of the GMACS spaceframe structure.

The IMF will completely outline much of the instrument subsystems, which allows the instrument to be placed on many of its sides for assembly, storage, shipping, and maintenance. This reduces the need for a specialized instrument cart to be used at all times during the instrument development process. The IMF will also be used as a natural attachment structure for all the side paneling to form the environmental enclosure to keep out stray light and foreign objects as well as stabilize the internal temperature.

### 3. FOCAL PLANE ASSEMBLY

The focal plane assembly mounts to the top end of the optics bench. This section contains the guide and acquisition cameras, the slit mask exchange mechanism (SMEM), and the fiber slit deployment mechanism, as seen in Figure 4. These systems are described in more detail in the following sections.

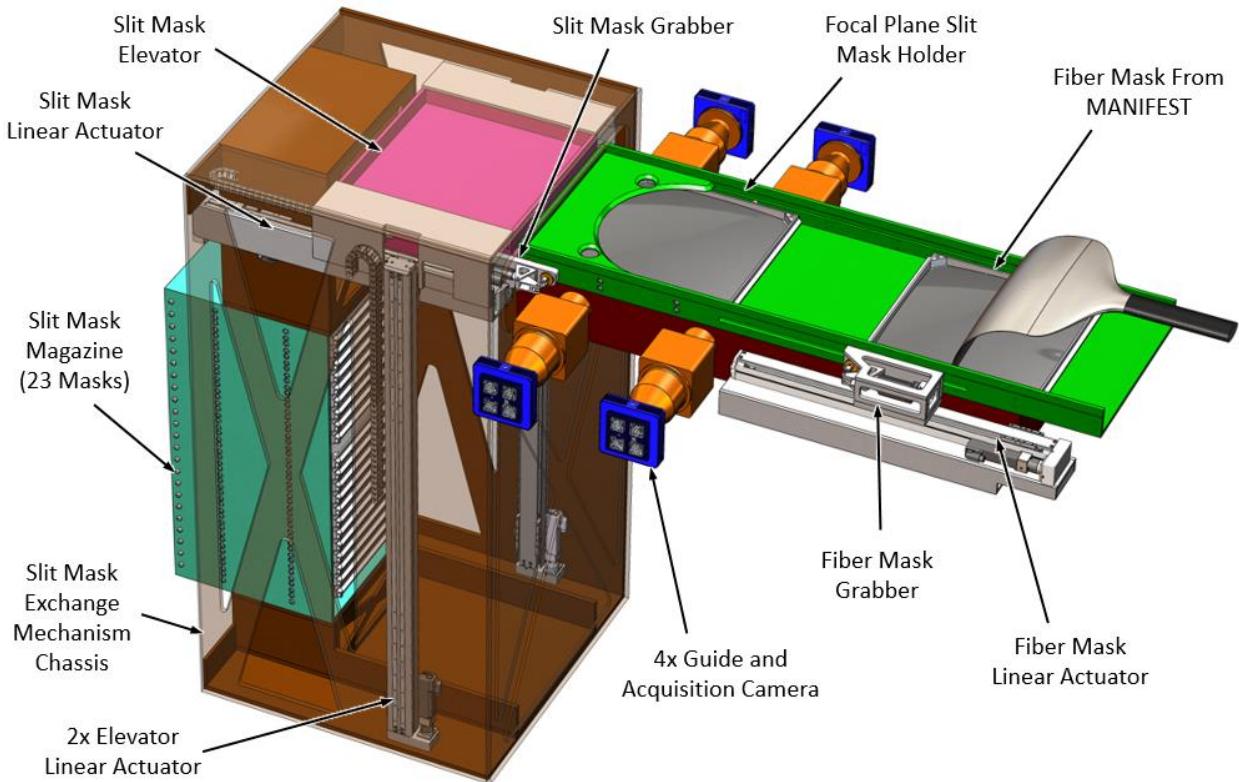

Figure 4. Section view of the focal plane assembly.

#### 3.1 Guide and acquisition cameras

The focal plane assembly will carry four alignment and acquisition cameras as seen in Figure 4. These cameras are in a fixed location behind the focal plane, each having  $\sim 1$  arcminute field of view. The acquisition and alignment cameras will be in fixed locations behind reference holes cut in every slit mask. They will allow precision alignment of the slit masks relative to reference stars that can be positioned appropriately on the CCDs. The density of reference objects on the sky should be very high, since the GMT can quickly detect extremely faint objects.

In future designs, one of the alignment and acquisition cameras may be replaced by another camera on a multi-axis rail system. This camera can be robotically positioned under slits to verify the alignment with its target on the sky. We will also investigate another technique to do the slit mask alignment using the actual GMACS red and blue cameras. By rotating the cameras and gratings to be on axis with their collimators, the red and blue cameras can take an image of the slit mask and targets to verify the alignment.

#### 3.2 Slit mask exchange mechanism

In order to observe multiple objects in different fields throughout the night, a jukebox-style exchange mechanism will be used to move 23 different slit masks into the focal plane and back into a storage magazine. The slit masks are 500 mm x 500 mm in size and will be curved to follow the best focal surface of the telescope, as shown in Figure 5. The cartridge

will use rails and rollers to translate into the storage magazine, elevator and focal plane observing locations. While in the focal plane holder, a slit mask will be captured kinematically and be held in place with a stability of ~10 microns.



Figure 5. Concept of the GMACS slit mask in its cartridge.

To keep the slit mask from being over-constrained, the magazines will use vee groove guide wheels on the left side and crowned rollers on the right. In addition, the upper wheels and rollers will be on flexures that allow them to adjust for varying rail separations. While translating in and out of the elevator, the tracks will remain in contact with at least two pairs of guide wheels at any time. Examples of these roller are shown in Figure 6.



Figure 6. Commercial off-the-shelf vee groove guide wheels and crowned rollers<sup>[9]</sup> that could be used to precisely move and hold the GMACS slit masks.

In the exchange mechanism, the slit mask elevator moves the slit masks from the magazine to the focal plane position. The system uses four linear actuators to securely move the slit mask from the magazine to the focal plane. The slit mask (horizontal) linear actuator extracts the mask from the magazine, and two vertical linear actuators translate the slit mask elevator to the position of the focal plane where the mask is inserted with the slit mask (horizontal) linear actuator. Both can be seen in Figure 4. The last linear actuator is part of the grabber system and uses a linkage system to engage a detent on the mask cartridge while riding on the slit mask (horizontal) linear actuator, as seen in Figure 7.

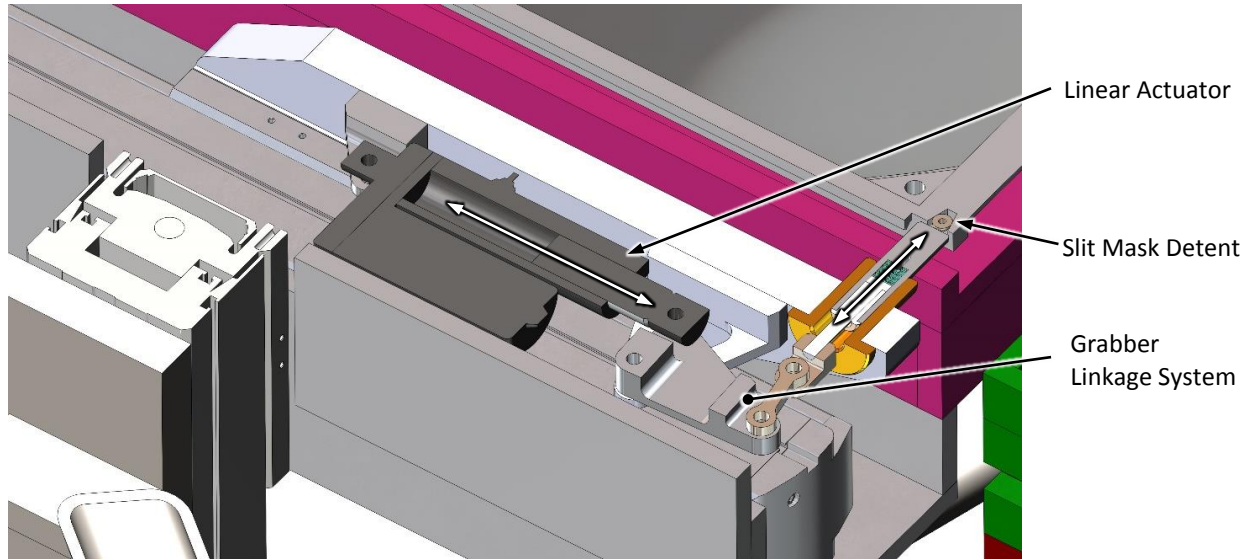

Figure 7. Section view of the slit mask grabbing system.

### 3.3 Fiber mask deployment mechanism

When GMACS is used with MANIFEST, the fiber mask is deployed to feed light into the optical system. The mask will position thousands of fibers into GMACS's focal plane to allow for higher spectral resolution and wavelength coverage of selected fibers. MANIFEST will reposition the fibers on its end using its "starbug" fiber positioning system, which allows them to quickly reconfigure to observe new targets over the full telescope field of view. More information on MANIFEST<sup>[6]</sup> can be found in the 2016 SPIE paper on the instrument.

To receive the fiber mask, GMACS must be in its stored position within the GIR and MANIFEST must be in the deployed position of the GIR. MANIFEST will handoff the fiber mask from its system by sliding it into the rollers next to the slit mask holder. The fiber mask's grabber will engage with the fiber mask's detent, which will allow for a linear actuator to move the fiber mask into the focal plane. The fiber mask grabber will practically be the same as the slit mask grabber. The fiber mask and its deployment mechanisms can be seen in Figure 4.

## 4. OPTICS MODULE

The optics module contains all of GMACS's optics for the spectrograph. The field lens, dichroic, fold mirror, compensator, collimators, gratings, and cameras can be seen in Figure 8. It also contains systems that independently articulate and hold the cameras and gratings at different angles. This is to accommodate the requirement to use multiple grating resolutions. In low resolution mode ( $R \sim 1000$ ) and high resolution mode ( $R \sim 6000$ ) the collimator-camera angle must be  $\sim 18.2^\circ$  and  $\sim 88.9^\circ$ , respectively. The optics module systems are described in more detail in the following sections.

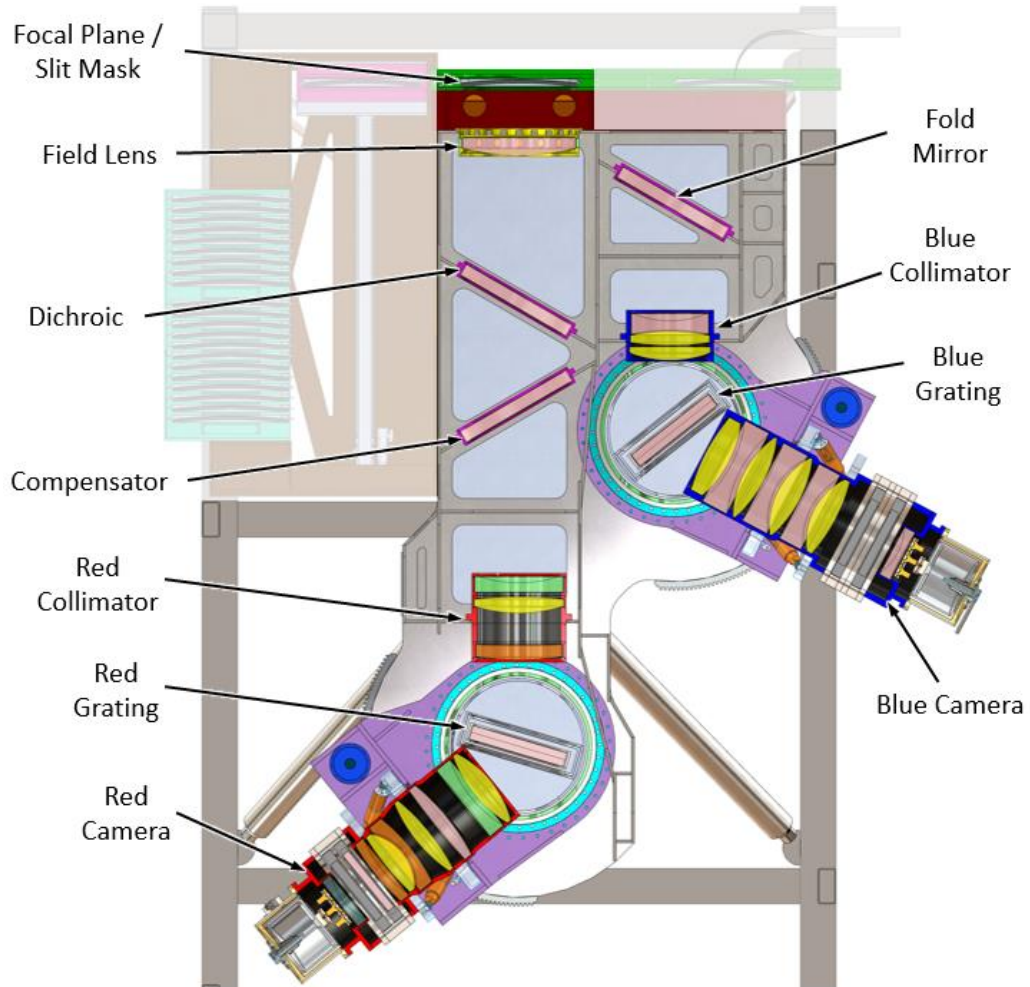

Figure 8. Section view of the GMACS optics module's primary subsystems.

#### 4.1 Field lens

The field lens is the first and largest optic in GMACS. It is a 488mm diameter silica lens that weighs 24.6kg. We plan to adapt a cell design similar to the one used in the DECam instrument<sup>[7]</sup> and in the MMT's wide field corrector<sup>[8]</sup> since these designs have proven to work well for large lenses. To account for differentials in the coefficient of thermal expansion (CTE), this design utilizes invar cells with room temperature vulcanization (RTV) pads to hold the lens and flexures to attach the cell to the steel frame. Our concept is shown in Figure 9.

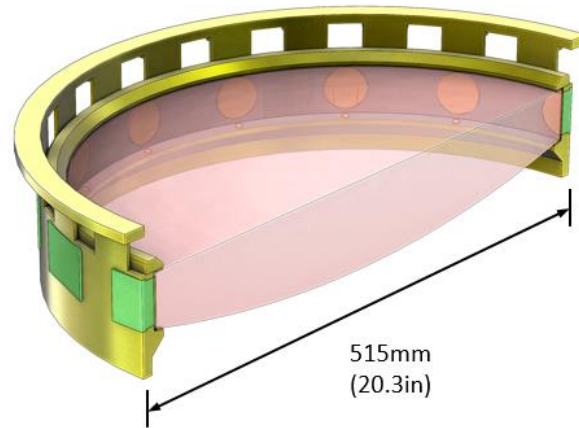

Figure 9. Section view of the field lens in its cell.

#### 4.2 Collimator, dichroic and cameras

The lens barrel/cell concepts for the collimator, dichroic and cameras optomechanical systems currently do not show precisely how they hold the optics, but the future design will be based on the cells used in the FourStar infrared camera<sup>[10]</sup> and the SDSS spectrographs<sup>[11]</sup>, which are known to work well. These cells will use roller pin flexures and glass-filled Teflon plugs to hold the lenses in alignment over varying temperatures. Figure 10, Figure 11, and Figure 12 below show the current details of the collimator assembly, blue camera, and red camera, respectively. Each camera will also have a Bonn shutter<sup>[12]</sup> before the detector window to control the exposure time on each channel and a filter exchange mechanism. The filters can be used to block orders of light or allow for highly multiplexed spectra over a narrow range of wavelengths.

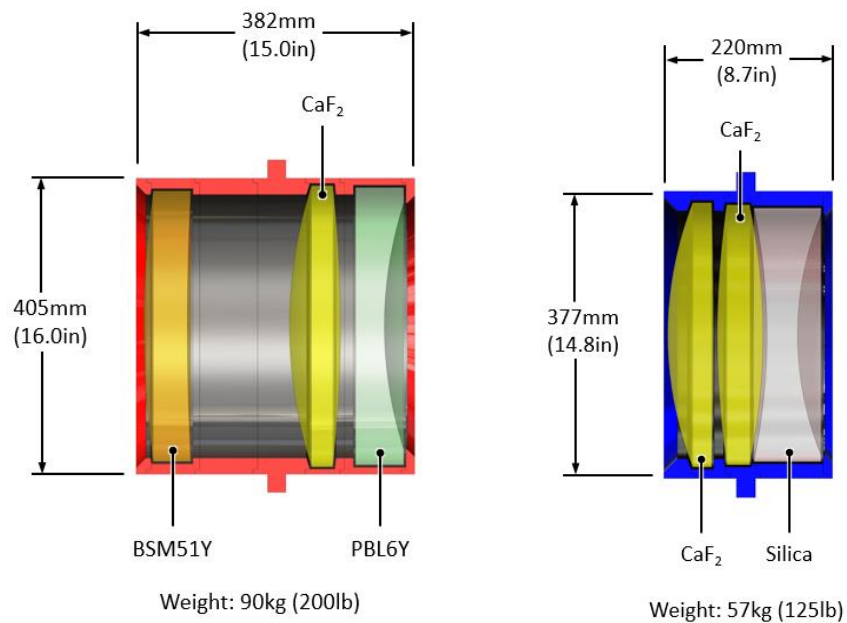

Figure 10. Section view of the red (left) and blue (right) collimator assemblies.



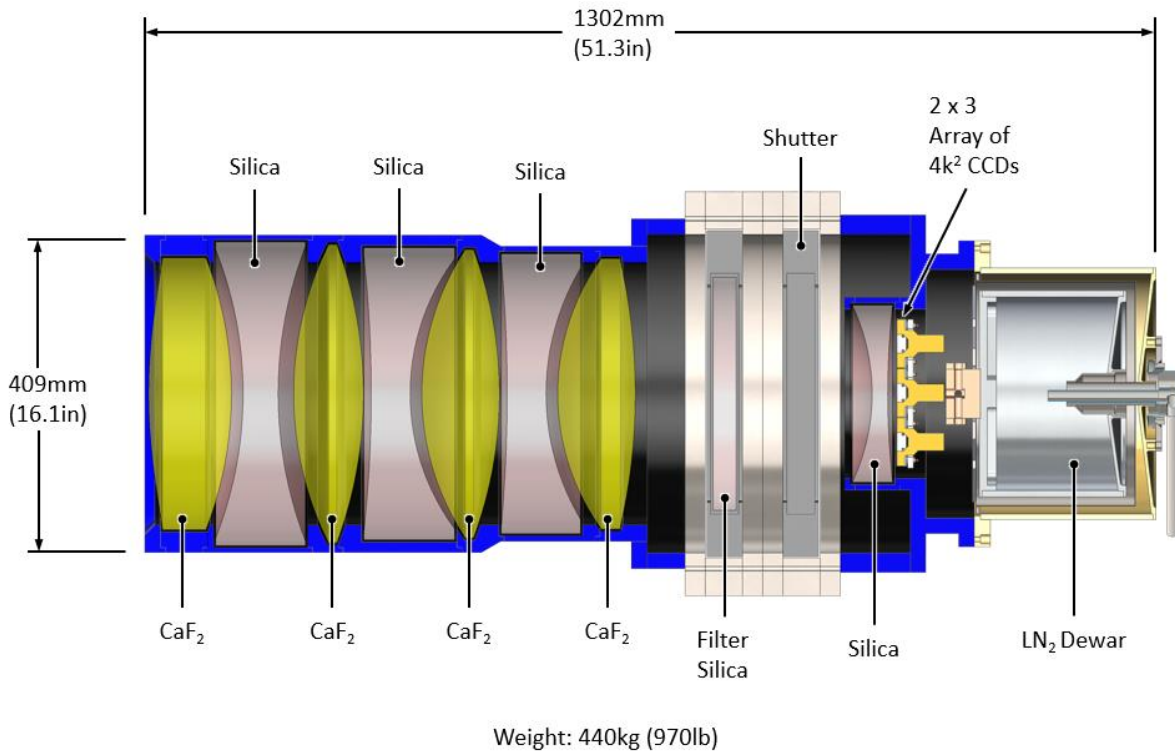

Figure 11. Section view of the blue camera showing the lens arrangement, cells, filter, shutter, CCD and its cryostat.

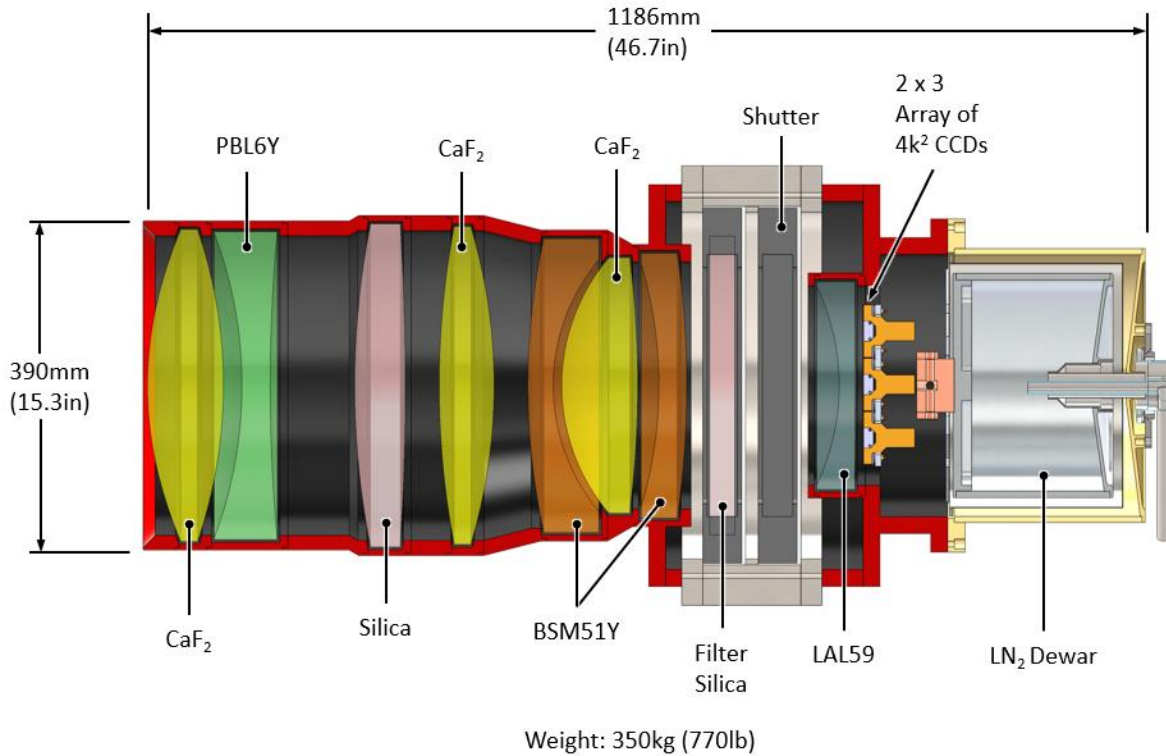

Figure 12. Section view of the red camera showing the lens arrangement, cells, filter, shutter, CCD and its cryostat.



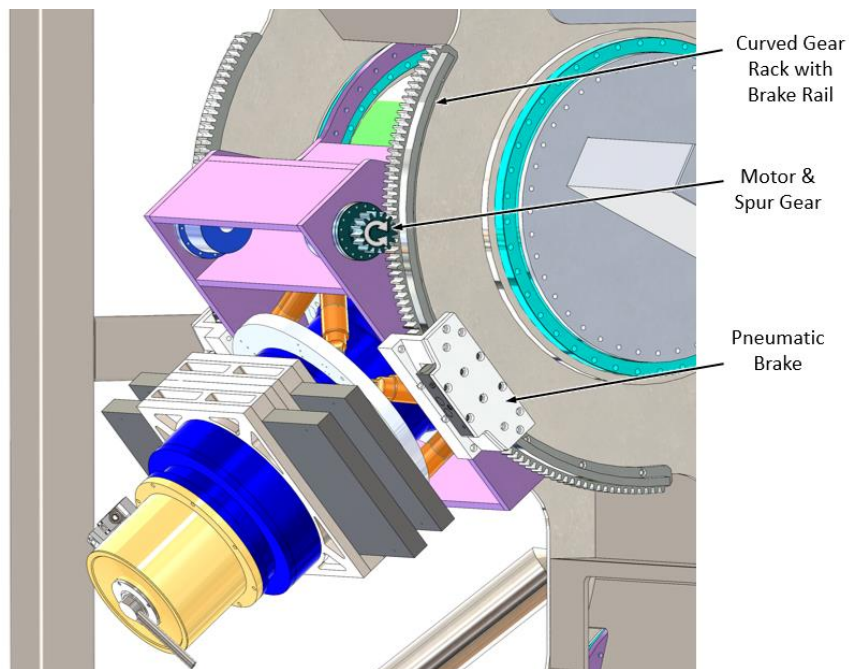

Figure 14. Motor and brake system used to move and hold a camera in various orientations relative to each grating.

#### 4.2.2 Detector and cryostat

A cryostat holds the detector mosaic for each camera. Each detector assembly is formed by a 2x3 mosaic of 4k<sup>2</sup> detectors with a pixel pitch of 15 $\mu$ m. An example detector array is shown in Figure 15.

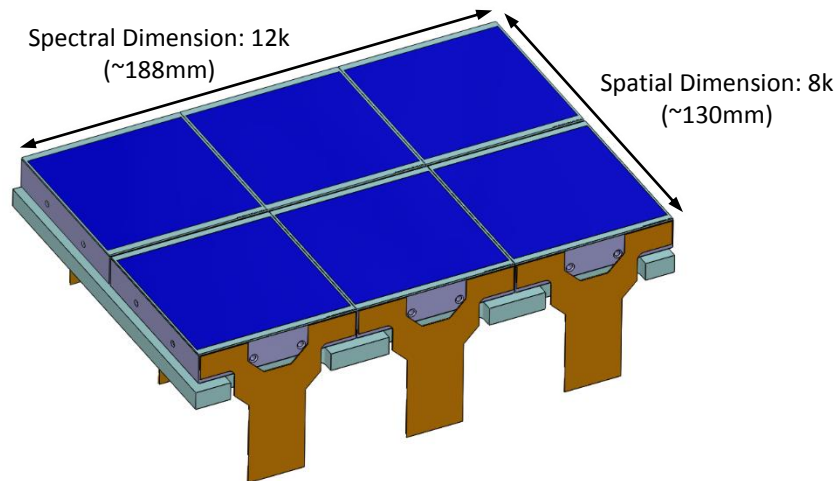

Figure 15. 2x3 CCD mosaic made from 4k<sup>2</sup>, 15 $\mu$ m detectors.

We currently plan to use liquid nitrogen cooling for the detectors. Some thought has also been put into using cryo-coolers, but reliability and excess waste heat are a concern. A future trade study will examine possible cooling mechanisms, the cooling requirements of GMACS, and the GMT facility standards to make the final determination.

To determine the approximate size of the liquid nitrogen dewar, a heat flow analysis was performed on the cryostat system. To aid in illustrating the system, the expected heat sources and transfer methods are shown in Figure 16. We determined in order to keep the detector at 140K, ~16.2W of heat will have to be removed by the liquid nitrogen vaporization. Knowing liquid nitrogen's heat of vaporization, the system will need 0.36L of liquid nitrogen per hour. If we only want to refill the dewar once per day, ~8.75L of liquid nitrogen will be needed, but the tank will need an internal volume twice that (17.5L) to prevent the liquid nitrogen from flowing out of the vent tube as the gravity vector changes.

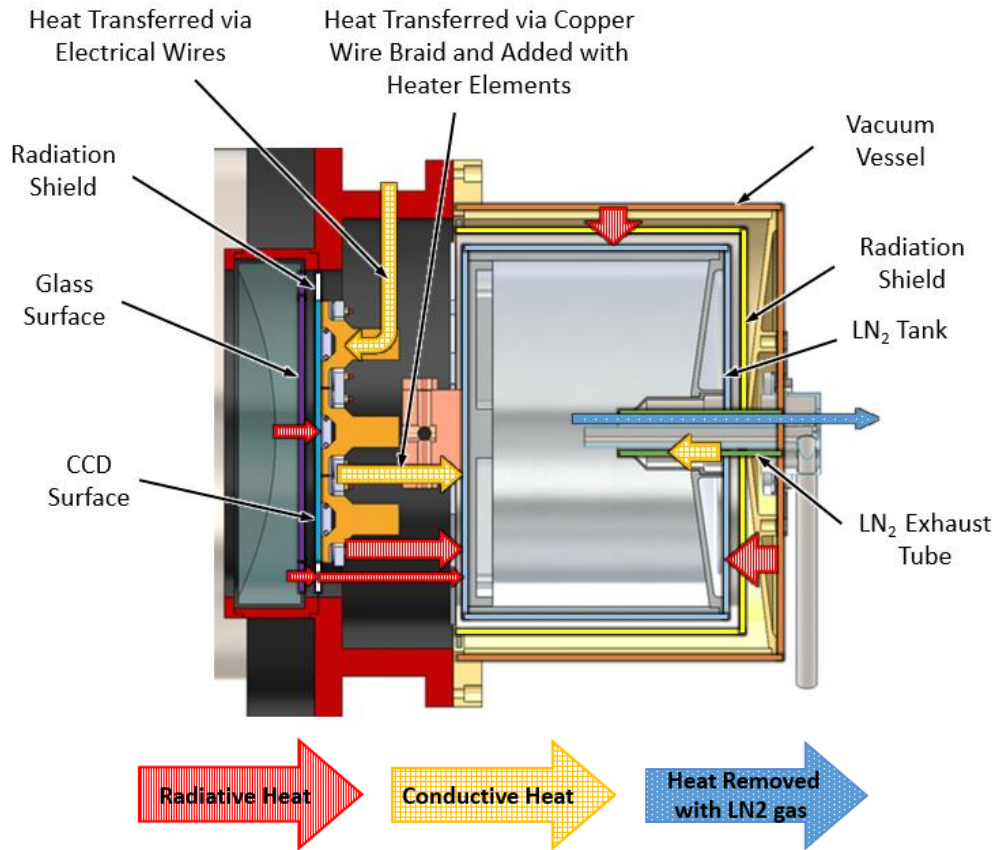

Figure 16. Paths of heat transfer within the detector cryostat.

### 4.3 Grating exchange mechanism

The grating exchange mechanism selects which grating will be used during each observation. It is only required to hold two gratings, but a third position has been added to leave room for future expansion. This would likely be used for a medium resolution grating. Figure 17 shows how the three gratings will be positioned in a row and can translate into different positions.

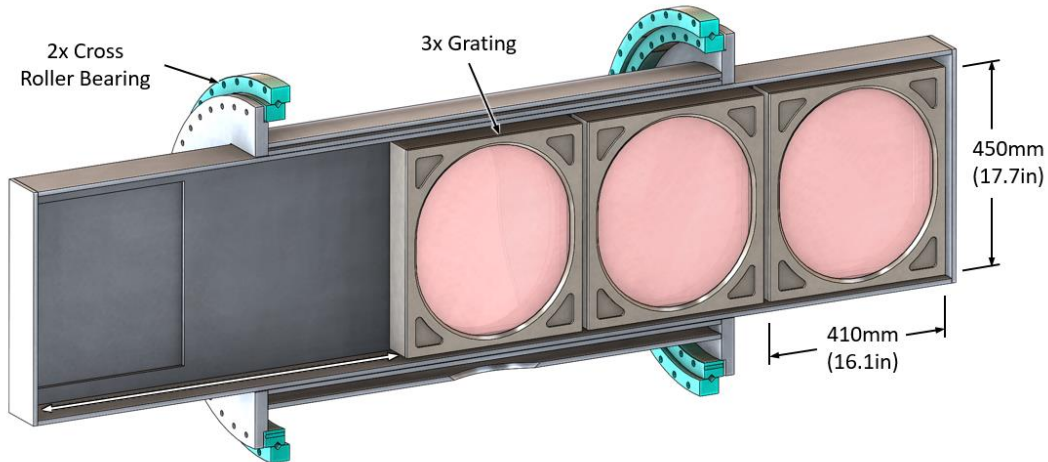

Figure 17. Opened view of a grating exchange mechanism.

#### 4.3.1 Grating turret rotation

Each grating turret rotates on two sets of cross roller bearings (ID=675mm (26.5in)). Their rotational range of motion is  $\sim 45^\circ$  relative to the optical axis. Rotation is driven by a cylindrical linear actuator which provides simple backlash free motion. Rotational tracking is not yet finalized, but options include linear potentiometer (baseline), an encoder on the rails, or simple open loop operation.

#### 4.3.2 Grating translation mechanism

The grating translation drive works with two sets of vee groove guide wheels that ride on parallel tracks to provide the requisite linear motion. The motive force is provided by a belt drive system, while limit switches set range of motion and hard stops preclude over-travel. The set of gratings are able to translate 850mm ( $\sim 33.5$ in).

## 5. FLEXURE

Gravity-induced image motion is a common issue for spectrographs mounted at the Gregorian or Cassegrain focus of a large telescope. As the telescope tracks the sky, the gravity vector changes relative to the instrument. Hence, gravity-induced deflections within the spectrograph structure change over time and alter the position and orientation of the optical elements housed within the structure. These subtle shifts of the optics translate into degradation and motion of the focused images at the camera detector focal plane, which ultimately reduces resolution and spectral stability. This problem is particularly acute for large instruments.

### 5.1 Simulation

To help understand how gravity-induced deflections will affect our system, simulations are made to estimate the expected deflections. With these numbers, we hope to determine how much compensation will be required along with areas that will need to be stiffened or lightened. These deformation values can also be fed into the ZEMAX optical tolerance analysis and determine the impact on the spectrograph's optical performance at different gravity vectors.

Finite element analysis (FEA) for the current system has not been performed at this time, so the FEA ran on the 2016 version of GMACS<sup>[4]</sup> will be referred to for this paper. We expect the new conceptual design to be much stiffer than the previous one since the frame will no longer be cantilevered. In the previous simulations, we ran three FEAs with differing gravity vectors to determine the deflection at some of the worst case scenarios. The results are tabulated in Table 2.

Table 2. Results of the preliminary FEA used to find the deflection of each camera focal plane at various instrument orientations.

Instrument Orientation	Red Camera CCD						Blue Camera CCD					
	X Shift Spatial	Y Shift Spectral	Z shift Focal	$\theta_x$	$\theta_y$	$\theta_z$	X Shift Spatial	Y Shift Spectral	Z shift Focal	$\theta_x$	$\theta_y$	$\theta_z$
	(mm)	(mm)	(mm)	(°)	(°)	(°)	(mm)	(mm)	(mm)	(°)	(°)	(°)
60° about X	-0.074	0.833	0.383	0.000	0.017	0.000	-0.031	0.680	-0.410	0.014	0.002	0.002
60° about Y	-1.759	0.008	-0.072	0.000	0.375	0.008	-1.457	-0.154	-0.084	0.005	0.006	0.006
Zenith (0°)	0.044	0.085	-0.149	0.000	0.041	0.001	-0.026	-0.248	-0.127	0.006	0.001	0.001

## 5.2 Compensation

To compensate for the expected deflection, a hexapod will be used in a closed loop system to orient each camera into its optimal position. Figure 18 shows a concept of how the blue camera could be mounted to a hexapod made by Physik Instrumente. This hexapod is expected to translate the camera  $\pm 2.5\text{mm}$ ,  $\pm 2.5\text{mm}$  &  $\pm 0.5\text{mm}$  in X, Y and Z, respectively, and rotate it  $\pm 0.5^\circ$  in tip, tilt and clock. From Table 2, the hexapod specifications should meet the required compensation amounts, but we will continue to investigate ways to reduce deflections.

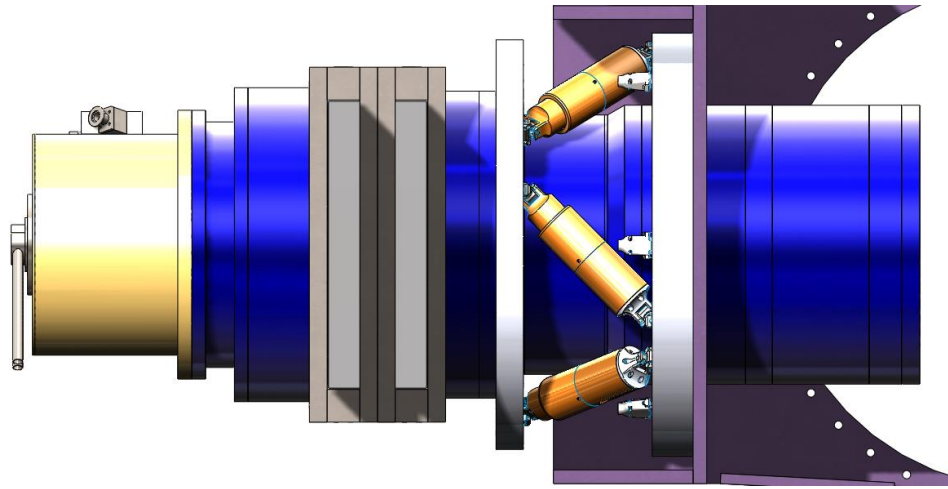

Figure 18. Hexapod used to compensate for gravity induced deflections.

To provide feedback for the misalignments in the closed loop flexure compensation system, the flexure will have to be tracked in real time. We are currently investigating two strategies to accomplish this tracking. The first is to send laser beams through the system and measure where they land on quad-cells near the focal plane to track the cameras' relative positions. The laser beam wavelength will be outside the science wavelengths to avoid contaminating the data. The second strategy is to use a network of Absolute Distance Meters (ADMs) like the ones used in GMT's telescope metrology system (TMS)<sup>[13]</sup>. The ADMs GMTO has been evaluating are made by Etalon Absolute Multiline Technology (EAMT). The ADMs use an emitter and reflector to measure the relative distance between the two points where they are mounted. With six channels it is possible to measure the relative distance and rotation between two objects.

## 6. CONCLUSIONS

GMACS's current conceptual design is still under development, but we have made significant progress advancing the design from the 2016 concept. In our models we have designed packages for the optics, structures to transfer the instrument load to the GMT, mechanisms to exchange slit masks and gratings, and articulation systems to rotate the cameras and gratings. Simulations on GMACS's gravity-induced deflections have shown we are in range of the hexapod compensation system. All the major subsystems are accounted for in the current conceptual design, but they all still require additional refinement.

## ACKNOWLEDGEMENTS

Texas A&M University thanks Charles R. and Judith G. Munnerlyn, George P. and Cynthia W. Mitchell, and their families for their support of astronomical instrumentation activities in the Department of Physics and Astronomy.

Please add this to the acknowledgments: "D. Williams was supported by NSF grant AST-1560223, REU Site: Astronomical Research and Instrumentation at Texas A&M University."

## REFERENCES

- [1] DePoy, D. L., Marshall, J. L., Cook, E., Froning, C. S., Ji, T., Jones, D. J., Lee, H., Mendes de Oliveira, C., Pak, S., Papovich, C., Prochaska, T., Ribeiro, R., Schmidt, L. M., Taylor, K., "The Giant Magellan Telescope multi-object astronomical and cosmological spectrograph (GMACS)," Proc. SPIE 9908, Ground-based and Airborne Instrumentation for Astronomy VI, 990879 (2016).
- [2] Schmidt, L., Ribeiro, R., Taylor, K., Jones, D., Prochaska, T., DePoy, D. L., Marshall, J. L., Cook, E., Froning, C. S., Ji, T., Lee, H., Mendes de Oliveira, C., Pak, S., Papovich, C., "Optical design concept for the Giant Magellan Telescope Multi-object Astronomical and Cosmological Spectrograph (GMACS)" Proc. SPIE 9908, (2016)
- [3] Smee, S. A., Prochaska, T., Shectman, S. A., Hammond, R. P., Barkhouser, R. H., DePoy, D. L., Marshall, J. L., "Optomechanical design concept for GMACS: a wide-field multi-object moderate resolution optical spectrograph for the Giant Magellan Telescope (GMT)," Proc. SPIE 8446, Ground-based and Airborne Instrumentation for Astronomy IV, (2012).
- [4] Prochaska, T., Sauseda M., Beck J., Schmidt L., Cook E., Darren, D. L., Marshall J. L., Ribeiro, R., Taylor, K., Jones D., Froning C., Pak S., Mendes de Oliveira, C., Papovich C., Ji, T. J., Lee, H. I., "Optomechanical design concept for the Giant Magellan Telescope Multi-object Astronomical and Cosmological Spectrograph (GMACS)," Proc. SPIE 9908, Ground-based and Airborne Instrumentation for Astronomy VI, (2016);
- [5] <https://www.mero.de/>
- [6] Lawrence, J. S., Ben-Ami, S., Brown, D. M., Brown, R., Case, S., Chapman, S., Churilov, V., Colless, M., Content, R., DePoy, D. L., Evans, I., Goodwin, M., Jacoby, G., Klauser, U., Kuehn, K., Lorente, N. P. F., Mali, S., Marshall, J. L., Muller, R., Nichani, V., Pai, N., Prochaska, T., Saunders, W., Schmidt, L., Shorridge, K., Staszak, N. F., Szentgyorgyi, A., Tims, J., Vuong, M., Waller, L., Zhelem, R. "The MANIFEST Prototyping Design Study," Proc. SPIE 9908, (2016).
- [7] Doel, P. , Brooks, D. , Antonik, M. L. , Flaugher, B. L. , Stefanik, A. , Kent, S. M. , Gutierrez, G. , Cease, H. P. , Abbott, T. M. , Walker, A. R. , DePoy, D. L. , Bernstein, R. A. , Worswick, S. " Assembly, alignment, and testing of the DECcam wide field corrector optics," Proc. SPIE 8446, Ground-based and Airborne Instrumentation for Astronomy IV, (2012).
- [8] Fata, R. G., Fabricant, D. G. "Design of a cell for the wide-field corrector for the converted MMT", Proc. SPIE 1998, Optomechanical Design, 32 (1993).
- [9] <http://www.bwc.com/products/components-accessories/dualvee.html>
- [10] Persson, S. E. , Barkhouser, R. , Birk, C. , Hammond, R. , Harding, A. , Koch, E. R. , Marshall, J. L. , McCarthy, P. J. , Murphy, D. , Orndorff, J. , Scharfstein, G. , Shectman, S. A. , Smee, S., Uomoto, A. "The FourStar infrared camera," Proc. SPIE 7014, Ground-based and Airborne Instrumentation for Astronomy II, (2008).
- [11] Smee, S. A. , Barkhouser, R. H. , Glazebrook, K. "Design of a multi-object high-throughput low-resolution fiber spectrograph for WFMOS," Proc. SPIE 6269, Ground-based and Airborne Instrumentation for Astronomy, (2006).
- [12] <http://www.bonn-shutter.de/>
- [13] Rakich, A., Dettmann, L., Leveque, S., Guisard, S., "A 3D metrology system for the GMT," Proc. SPIE 9906, Ground-based and Airborne Telescopes VI, (2016).