

## VIRUS

## VIRUS Meeting Notes

## What is VIRUS?

VIRUS stands for Visible Integral-Field Replicable Unit Spectrographs. VIRUS is part of the HETDEX project, which will enable astronomers to map portions of the universe and investigate the role of dark energy. For more information please visit <http://www.hetdex.org/hetdex/virus.php>

## How is TAMU Astro-Physics involved?

TAMU is involved in various levels of the VIRUS project from design to testing, which include:

- Creating all the alignment and assembly fixtures necessary to produce 150 VIRUS spectrograph units. Currently, two alignment/assembly fixtures have been designed by TAMU.
- Collimator assembly fixture - The collimator is part of the spectrograph which holds the reflective mirrors, gratings, and the fiber optics, as shown below:

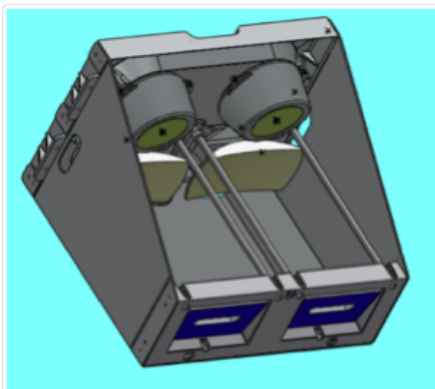

- The collimator assembly fixture will utilize two precision aligned plates on the base and top of the device, which will be used to guide the placement of all other components. The fixture is composed of a welded steel frame. Two tracks will be manufactured and attached to each side of the collimator to allow for a smooth transition between assembly fixtures. For ease of transition between assembly fixtures, there will be a bumper guard that can be placed on the collimator to prevent collisions with the collimator frame. The collimator with bumper can be seen below:

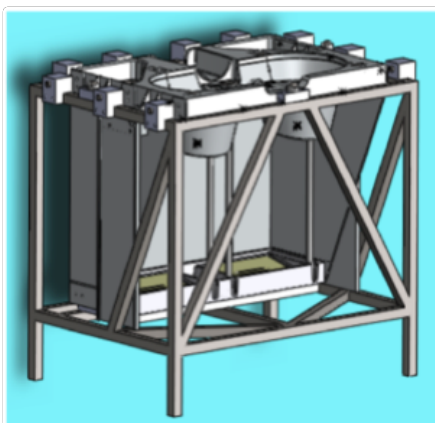

- The collimator assembly fixture will utilize two precision aligned plates on the base and top of the device, which will be used to guide the placement of all other components. The fixture is composed of a welded steel frame. Two tracks will be manufactured and attached to each side of the collimator to allow for a smooth transition between assembly fixtures. For ease of transition between assembly fixtures, there will be a bumper guard that can be placed on the collimator to prevent collisions with the collimator frame. The collimator with bumper can be seen below:

## RECENT DOCUMENTS

## VIRUS

December 9, 2010 at 6:40 AM

## VIRUS Management

December 9, 2010 at 6:23 AM

## VIRUS Management

December 8, 2010 at 11:38 AM

## What is VIRUS?

December 2, 2010 at 8:35 AM

## Notes

December 2, 2010 at 8:30 AM

## NOTIFICATIONS

- Include in All Activity  
 Email me when updated

## HISTORY

Sarah Buckingh...	12/9/2010 at 7:40 AM
Jennifer Marshall	12/8/2010 at 12:38 PM
Sarah Buckingh...	12/2/2010 at 9:35 AM
Sarah Buckingh...	12/2/2010 at 9:35 AM
Sarah Buckingh...	12/2/2010 at 9:32 AM

[Show more](#)

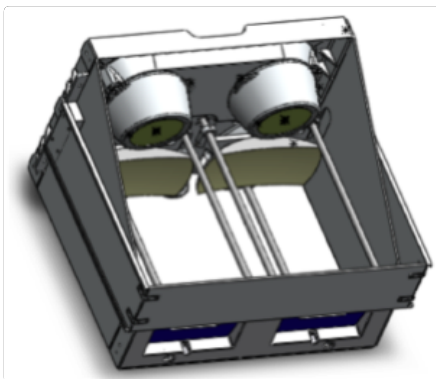

- Grating alignment fixture - Another important component of the spectrograph is the grating. The grating is an optical component that will diffract the light from the fiber optics into the cameras. In order to produce useable data the gratings need to be aligned with a precision of .5 degrees. In order to achieve this precision alignment Texas A&M University will create a fixture which passes light through the grating and into a detector which measures the angle. The fixture will pass light from an LED through an achromatic lens, into the grating. At the grating the light will become bent then pass through another achromatic lens and into a detector as shown below:

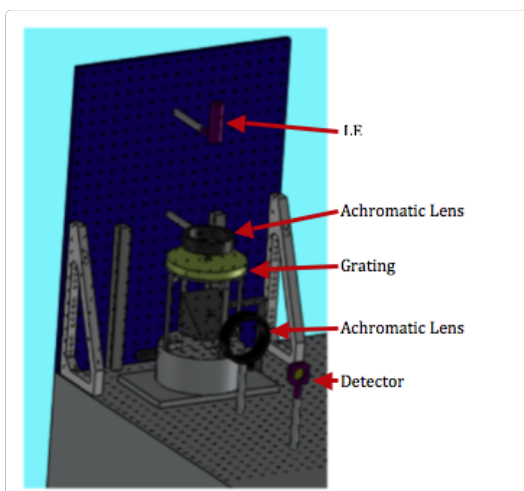

- Once the grating has been attaching to the housing it will be ready to use in the next assembly fixture which will attach it inside the collimator.
- Designing and testing the liquid nitrogen cooling system.
- In order to get the highest quality image, each spectrograph must be kept at extremely cold temperatures as low as  $-180^{\circ}\text{C}$ . To achieve this temperature, each camera pair will be equipped with a liquid nitrogen fed bayonet that removes heat by way of conduction. The figure below explains how the cooling process works:

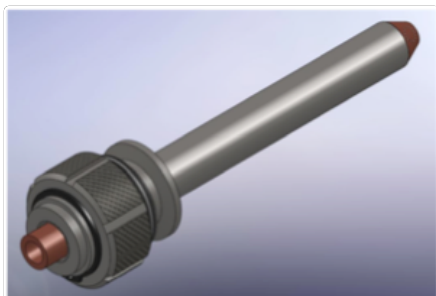

Liquid nitrogen enters the copper tube on the left side of the model. This copper tube comes into contact with the copper plug on the right side of the model which is in the camera environment. The liquid nitrogen boils at the contact point of the copper tube and plug which cools the entire system. The resulting nitrogen gas will travel back through the copper tube and attached hose line and escape into the ambient environment.

Researchers at Texas A&M and the University of Texas are jointly testing the feasibility of using a gravity fed liquid nitrogen cooling system for all 70 spectrograph camera pairs in VIRUS. These tests will be performed by constructing a test apparatus that will be heated by electric resistors and cooled by an array of liquid nitrogen "bayonets". The figure below shows how the test model will be built:



The liquid nitrogen transfer connections are at the top of each 4-way cross while the heat source is found at the bottom. A vacuum pump will evacuate the air from within the system. Once the heating process reaches a stable "hot" temperature, liquid nitrogen will be fed to the individual cooling systems via a gravity fed dewar. Construction of the liquid nitrogen transfer connections are being led by the Texas A&M Astro-Physics department and the Texas A&M Physics Machine Shop.